

Lithium Ion Battery Module

(4.4kw Class Lithium Ion Battery)

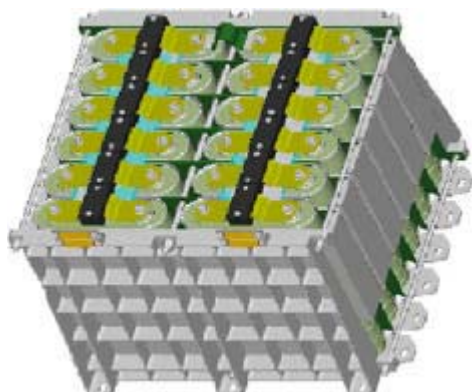

Features

- *Light weight : Over than 100 wh/kg
High specific energy
- *Small volume : Less than 32 wh/l
High energy density
- *Small number of cells for Battery
High discharge voltage (3.6V/one cell)
- *No trickle charge
Small self discharge current: 0.1%/day
- *No reconditioning operation
No memory effect
- *Long life : longer than 15 years
for GEO satellite and 7years for
LEO satellite

Block Diagram

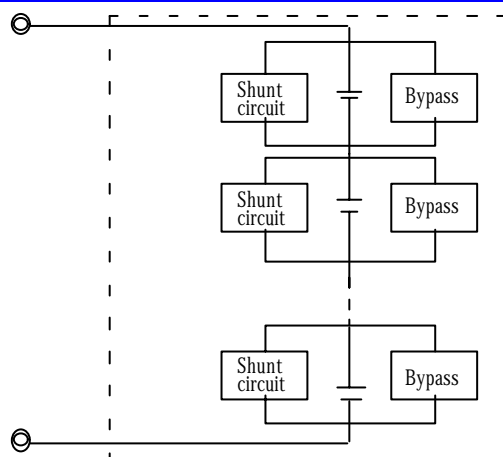

Protection

- *Overcharge: Shunt circuit on each cell protects overcharge by by-passing the charge current.
- *Open failure: By-pass switch on each cell protects open cell failure by closing the circuit.
- *Electrical insulation failure: Double insulation between cell case and chassis protects the failure.
- *Low temperature: Heater elements on the cell mounting structure protect the low temperature.

Performance Summary

<u>Items</u>	<u>Description</u>	<u>Remarks</u>
Voltage Range (V)	36 - 48	
Nominal Voltage (V)	43.2	
Capacity (Whr)	7560	
Discharge Current : Max. (A)	525	3C, 2 sec.
Discharge Current : Cont. (A)	175	1C
Life for LEO satellite	7 years (38,000 cycles)	@ DOD: 20%
Life for GEO satellite	15 years (1,500 cycles)	@ DOD: 56%, (Ave), 70% (max)
Resistance (mohms)	24	
QT Temperature Range (deg-C)	-10 to +35	
AT Temperature Range (deg-C)	0 to +25	
Weight (kg)	67.2	without mounting panel
Dimensions (mm)	420(W) x 408(L) x 298.4(H)	