

L-Band Parallel SSPA Assembly (PSA)

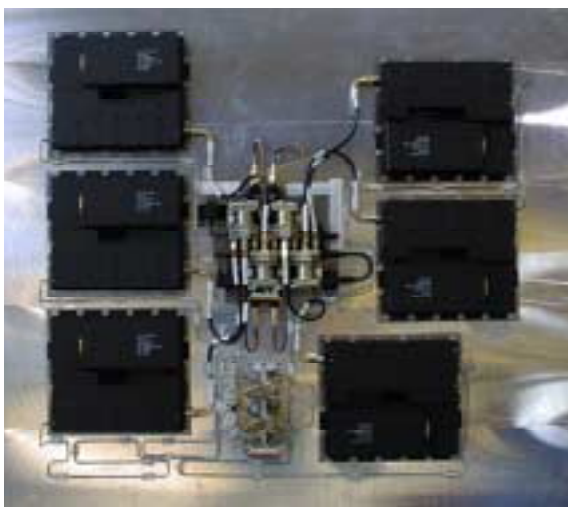

Features

- High RF output power with parallel SSPA operating
- Single input and Single output
- Switching strategy for SSPA redundancy

Heritage

- N-STAR a/b (S-Band)
- MTSAT MPA (L-Band)

Block Diagram

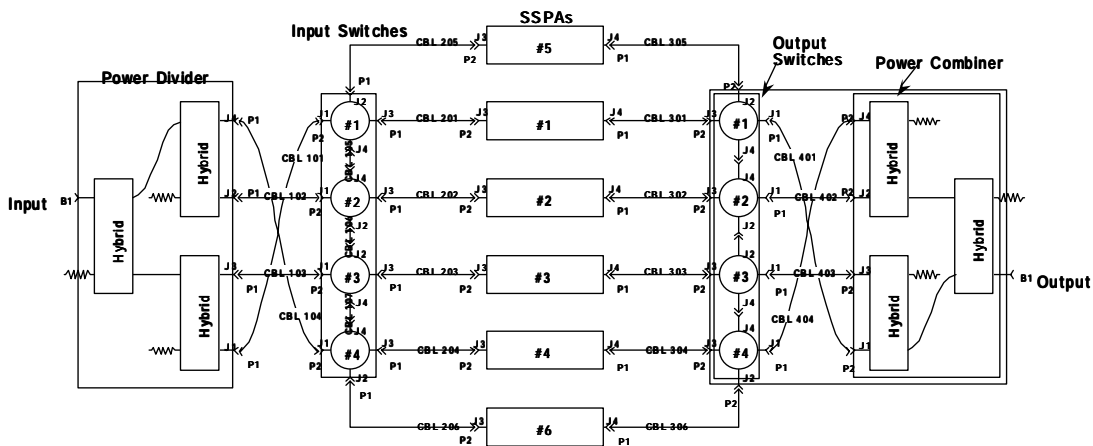

Performance Summary

<u>Items</u>	<u>Description</u>	<u>Remarks</u>
Operating Frequency Band (GHz)	1.5	10MHz Band Width
Output Power (w)	> 145	@NPR>16dB multi-tone
Gain (dB)	64 nominal	
DC Input Power (w)	577	@Rated output power (80w)
Efficiency (%)	25 nominal	
Mass (kg)	18.5 nominal	
Mission Life (years)	10	
Input Connector	SAM (Female)	
Output Connector	TNC (Female)	